



Brand: BendPak
Model: XPR-10A-168
Description: 10,000-Lb. Capacity Two-Post Lift / Extended Height Asymmetric Clearfloor

The Perfect Car Lift Solution

The powerful and secure XPR-10A-168 is an incredibly rapid two-post lift with a robust menu of features to increase efficiency and productivity. Extended height columns provide added overhead clearance and an adjustable width design allows you to choose the best setting for your specific space or vehicle lifting requirements. This true asymmetric lift features 30° rotated columns for added door-opening clearance and interior car access. The exclusive Tru-Metric carriage and arm design combines to give users the ability to load vehicles either symmetrically (centerline of vehicle at column) or asymmetrically (centerline of vehicle behind column).

A simple, yet highly sophisticated lift design keeps service and maintenance costs to a minimum, delivering lower operating expenses and higher productivity. If you're looking to make more money in less time than ever before, you'll find that the XPR-1 to your shop.



FREE 8-Pc. Truck Adapter Set



Features

- 10,000-lb lifting capacity
- Bolt-on 24" column extensions provide added overhead clearance
- Expandable top beam accommodates wide or narrow drive-thru configuration
- Padded overhead safety shutoff bar
- Exclusive Tru-Metric arm design for more versatile arm positioning
- 30° rotated single-piece columns
- Single-point safety release
- Drop-end arms provide a lower pad height
- Dual hydraulic direct-drive cylinders
- Oversized 53" tall carriage for superior strength and durability
- Electric / hydraulic power system
- Large, 17" x 19" A36 steel base plate
- Self-lubricating dura-glide UHMW polyethylene bearing system
- Safety locks in each column spaced every 3"
- Automatic arm restraints
- Heavy-duty 1/2" aircraft-quality equalizer cables
- Oversized cable sheave diameter reduces cable fatigue
- 8-piece truck and van adapter set standard
- Triple-telescoping arm design
- Versatile drop-in contact pads with stackable adapters
- ETL Approved.



Bolt-on 24" column extensions provide added overhead clearance.



Lift arms shown with optional foot guards

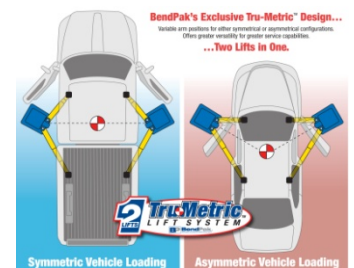

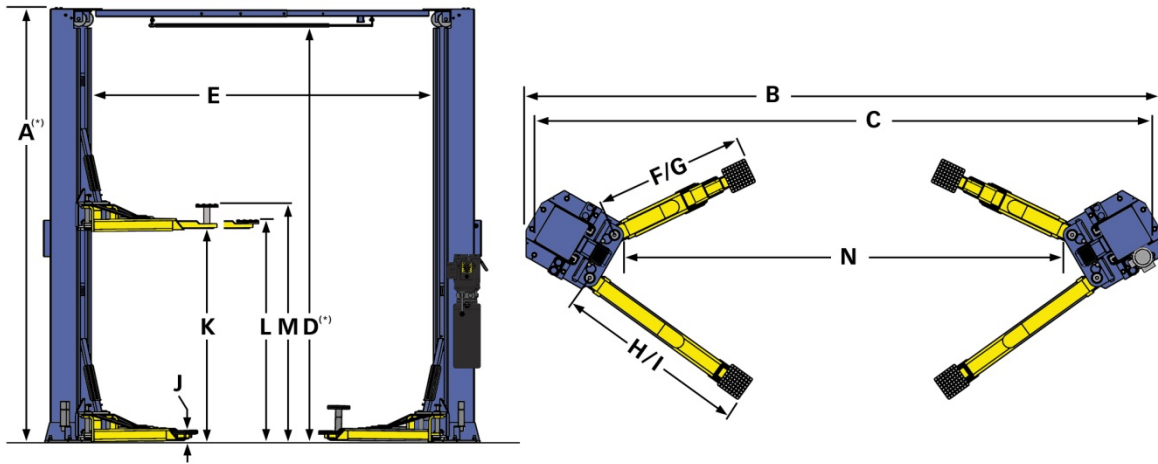

FLOORPLAN

TWO-POST MODEL / HEAVY-DUTY / EXTENDED HEIGHT / ASYMMETRIC

MODEL	XPR-10A-168
Lifting Capacity*	10,000 Lbs. / 4536 Kg.
*Max Capacity / Front Axle	5,000 Lbs. / 2268 Kg.
*Max Capacity / Rear Axle	5,000 Lbs. / 2268 Kg.
A - Height Overall: (*)	168" / 4267 mm.
B - Width Overall - NARROW CONFIGURATION	132" / 3353 mm.
B - Width Overall - WIDE CONFIGURATION	145" / 3683 mm.
C - Width Outside of Columns: (NARROW CONFIGURATION)	128" / 3251 mm.
C - Width Outside of Columns: (WIDE CONFIGURATION)	141" / 3581 mm.
D - Floor To Overhead Switch: (*)	165" / 4191 mm.
E - Inside Columns: (NARROW CONFIGURATION)	99" / 2515 mm.
E - Inside Columns: (WIDE CONFIGURATION)	112" / 2845 mm.
F - Reach (Front Arm Min.):	23-1/2" / 597 mm.
G - Reach (Front Arm Max.):	45-1/2" / 1156 mm.
H - Reach (Rear Arm Min.):	42-1/2" / 1079 mm.
I - Reach (Rear Arm Max.):	60" / 1524 mm.
J - Min. Pad Height:	4" / 102 mm.
K - Rise:	69" / 1753 mm.
L - Max Lift Height (Pad Only):	73" / 1854 mm.
M - Max Lift Height (6" Adapter):	79" / 2007 mm.
N - Drive-Thru Clearance: (NARROW CONFIGURATION)	89" / 22261 mm.
N - Drive-Thru Clearance: (WIDE CONFIGURATION)	102" / 2591 mm.
Motor (**)	220 VAC / 60 Hz. 1Ph.
Time of full Rise:	45 Seconds
Max Load Per Arm:	2,500 Lbs. / 1134 Kg.

*Features bolt-on 24" column extensions

** Special Voltages Available Upon Request.

The design, material and specifications are subject to change without notice.